

# ORIGINAL EV SERIES MOUSE VALVES

2-WAY & 3-WAY, N.O. OR N.C. VALVES



<b>Valve Type</b>	2-Way or 3-Way, N.O. or N.C.
<b>Medium</b>	Clean, dry air (40 micron filter)
<b>Pressure Range</b>	Vac. to 105 psig
<b>Nominal Power</b>	0.67 watts
<b>Response Time</b>	5 to 10 ms
<b>Temperature Range</b>	32 to 180°F
<b>Operating Range</b>	90 to 150% of rated voltage
<b>Voltage</b>	12 VDC or 24 VDC
<b>Mounting</b>	In-line or manifold mount
<b>Materials</b>	Nickel-plated brass body; nickel-plated steel housing, core, and spider
<b>Seal Material</b>	Nitrile standard, FKM, EPDM <sup>1</sup> and silicone <sup>1</sup> available
<b>More Details</b>	<a href="http://clippard.com/link/ev">clippard.com/link/ev</a>

<sup>1</sup>Minimum order quantity for EPDM or silicone seals

Clippard's original EV series valve design is a deceptively simple arrangement featuring a remarkably quiet, low power operation. The Clippard "spider" is the only moving part, and its motion to operate the valve is a mere 0.007" travel. As a result, this valve features an exceptionally long life—proven to last over 1,000,000,000+ cycles. Low voltage DC inputs move the spider, generating extremely fast response times of 5 to 10 milliseconds while using only 0.67 watts of power. The EV series is cool running and its compact, lightweight design makes it easy to mount in small spaces.

- 1,000,000,000+ cycle life
- Low vibration and noise
- 100% tested
- Low power
- Fast response time
- Compact and lightweight



Also available in Analytical,  
Corrosion-Resistant, Oxygen Clean,  
& Proportional versions

## QUICK CONNECT

Clippard ET valves feature spade lugs for simple, quick secure low voltage connections. Wire crimp-on spade lug connectors are available separately to adapt electronic wiring where necessary. Clippard original EV type valves are available in popular voltages with 18" wire leads. The EC model utilizes a 0.025" square pin connector.



## EASY MOUNTING

The complete line of EC, EV, ET and EW electronic valves are available with two mounting options. In-line base models have two #6-32 threaded, 7/32" deep mounting holes. Manifold models are equipped with a bottom stud, 5/32" long with #10-32 thread, which fits Clippard standard and special manifolds, accessory valves and subplates. Spanner holes in the valve body permit tightening.

# Clippard's Best-Selling EV Series Electronic Valve

Clippard EV series electronic valves are quiet and quick. These valves accept low voltage, low current signals and convert them into high pressure (100 psig) pneumatic outputs. Optional low pressure/medium flow (-L) and low pressure/high flow (-H) are available.

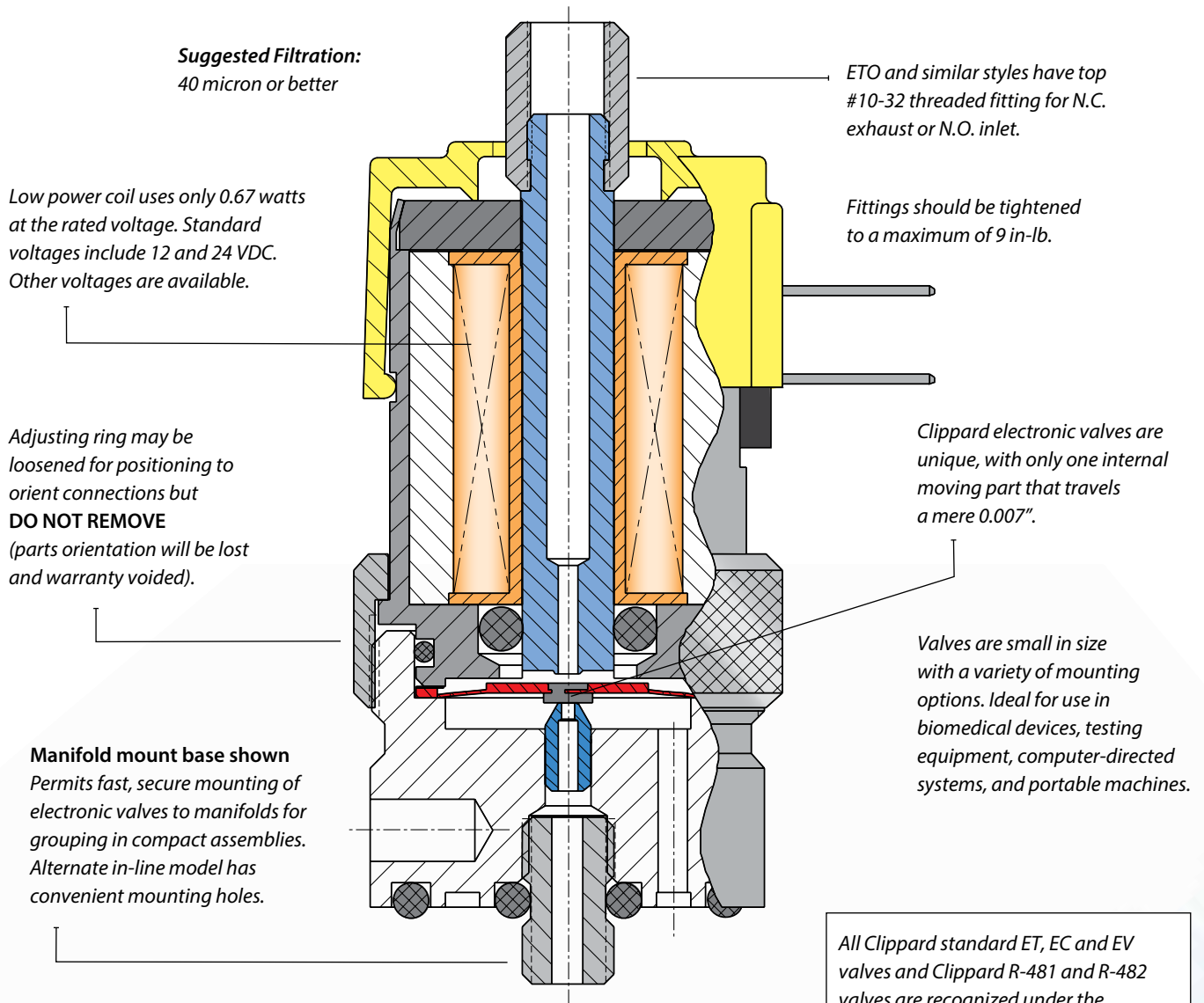

All Clippard standard ET, EC and EV valves and Clippard R-481 and R-482 valves are recognized under the Component Program of Underwriters Laboratories, Inc.

File No. MH 13573



Clippard Minimatic electronic valves are precision-built 2-Way or 3-Way control valves, utilizing a unique, patented, valving principle. There are no sliding parts. Complete poppet travel is a mere 0.007". As a result, low power consumption and exceptionally long life are major benefits of this design.

Clippard EV series valves are very quiet in operation and also very cool. The small, compact size of these valves make them well suited for a wide range of applications in biomedical devices, environmental test equipment, textile machines, packaging machinery, computerized industrial automation, and portable systems.

# ORIGINAL EV SERIES MOUSE VALVES



## STANDARD SERIES

2-Way and 3-Way manifold and in-line mounting. Normally-Closed and fully-ported versions.

## HIGH FLOW VERSION

A higher flow version is also available for 2-Way, Normally-Closed applications. Although manifold mounting is accomplished in the same fashion, the inlet is the annular port, and the outlet becomes the center port, through the convenient stud mount of the valve.

More Details: [clippard.com/link/ev](http://clippard.com/link/ev)

*Nickel-plated brass fitting*

*Electroless nickel-plated steel housing and core*

*Nitrile seals standard*

*Electroless nickel-plated brass body*

*Stainless steel stud and nozzle*

*(Manifold style valve shown)*

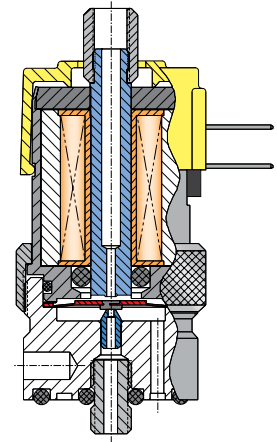

## CORROSION-RESISTANT SERIES

Clippard's Corrosion-Resistant Series (CR-) incorporates materials and construction that provides enhanced protection for valves used with mildly corrosive media such as moisture in air or gases. Where stainless steel is not possible, plating is incorporated to add life to wear components. A nickel-plated brass valve body is standard, but stainless steel may be substituted.

More Details: [clippard.com/link/cr-ev](http://clippard.com/link/cr-ev)

*Nickel-plated brass fitting*

*Stainless steel housing and core*

*Nitrile seals standard*

*Electroless nickel-plated Spider*

*(Manifold style valve shown)*

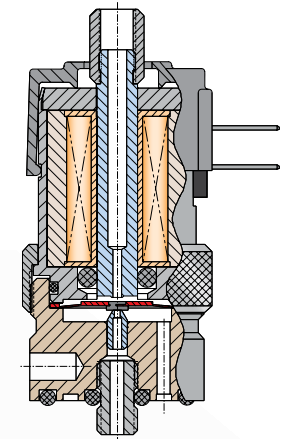

## ANALYTICAL SERIES

Clippard's Analytical Valve (A-) series combines the proven features of the "Mouse" series with the specific needs of the analytical industry, and for applications where cleanliness is especially important. Special materials, manufacturing and assembly processes make this valve perfectly suited for applications where internal cleanliness, bubble-tight operation, and long life are imperative.

More Details: [clippard.com/link/analytical](http://clippard.com/link/analytical)

*Integral fitting*

*No anaerobic sealant used*

*Larger cross section o-ring improves sealing*

*Cleaned per Clippard Standard ES-3.43*

*One-piece base eliminates many leak points*

*Outgassed FKM seals standard*

*(Manifold style valve shown)*

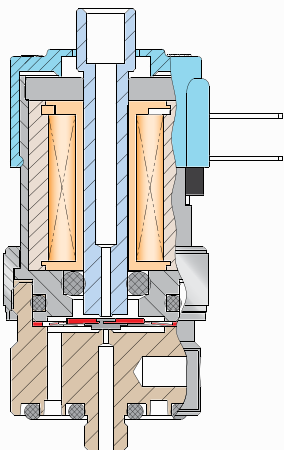

# ORIGINAL EV SERIES MOUSE VALVES

## OXYGEN CLEAN SERIES



All EV, ET, EC and EW series electronic valves with the "O-" part number option are available manufactured and assembled for use in oxygen-enriched environments for applications that are extremely sensitive to contamination.

More Details: [clippard.com/link/oxygen](http://clippard.com/link/oxygen)

- Valves are ultrasonically cleaned, assembled, inspected and tested in a cleanroom with a state-of-the-art positive pressure HEPA filtration system
- Both organic and inorganic contaminants, such as particulate matter and hydrocarbon oils, are removed
- No organic sealants, adhesives, or lubricants are used in the manufacturing process
- Component parts are lubricated with oxygen-compatible PFPE grease, only as needed for assembly
- Individual testing and inspection is accomplished utilizing compressed Nitrogen and ultra-violet light

*Integral fitting*

*No thread sealant*

*All wetted parts cleaned per Clippard Standard ES-3.41*

*Electroless nickel-plated steel housing and core*

*FKM seals*

*Stainless steel nozzle*

*Electroless nickel-plated brass body*

*Integral stud*

*PFPE lubricant*

*(Manifold style valve shown)*

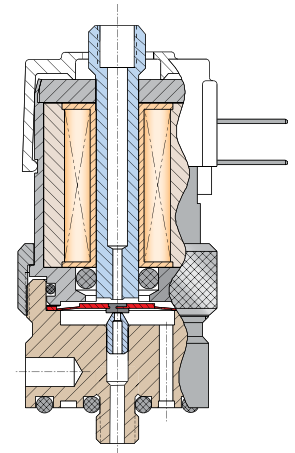

Valves are assembled in Clippard's clean room, which exceeds **ISO 13485** specification for medical devices.

ELECTRONIC VALVES



## ECN, EVN, ETN MOUSE VALVES



Normally-Open, manifold mount to allow Normally-Closed and Normally-Open valves on the same manifold.

More Details: [clippard.com/link/ecn](http://clippard.com/link/ecn)

*Integral fitting*

*Armature "spider" above coil*

*Mounts side-by-side with Normally-Closed version*

*(Manifold style valve shown)*

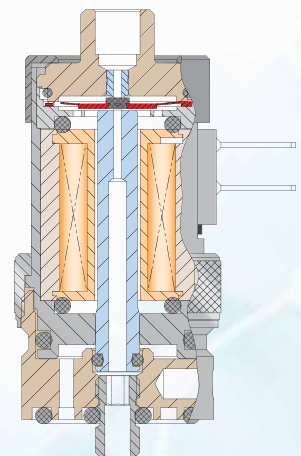

## CLEANING CAPABILITIES



It's no surprise that the cleaner your valve is, the less it will leak. However, cleanliness is also important in other ways, such as for medical applications where fluid flowing through the valves may be entering a person's body or for applications in the food and beverage industry. In these cases, the valves must not only be cleaned of any particulate matter, but also of any harmful substances used in the normal machining or assembly process. When cleanliness matters, you can count on Clippard to provide the special cleaning, assembly, and testing processes your demanding applications require.

Each of Clippard's manufacturing facilities are equipped with custom isolation enclosures designed specifically for the pharmacy and biotech industries. These clean rooms provide enclosed, controlled environments for the assembly, inspection, and testing of sensitive valves and equipment. They help to protect against airborne contaminants, ultraviolet rays, and temperature fluctuations. Additionally, the modular nature of these enclosures allows Clippard to quickly and easily expand capacity to meet special requirements or increased demand.

---

## ANALYTICAL SERVICE

Valves intended for low-leak, high precision environments, such as laboratories, often require higher quality cleaning and handling to limit contamination. Clippard's analytical "A-" series electronic valves provide a standard valve that meets these requirements. The assembly standards for these valves can also be applied to customer specials.



- Valves are designed with reduced leak paths
- Valves are ultrasonically cleaned, assembled, inspected, and tested in a clean room area
- Seals are cleaned ultrasonically with high purity alcohol, then heated to outgas before assembly
- Cleaned parts are inspected under white and ultraviolet light to insure the absence of particulate and hydrocarbon contamination
- Components are lubricated with isopropyl alcohol, only as needed for assembly
- Valves are tested using high purity compressed nitrogen in place of standard shop air
- Valves are pressure decay leak tested
- Finished valves are double bagged in heat sealed polyethylene bags to ensure cleanliness

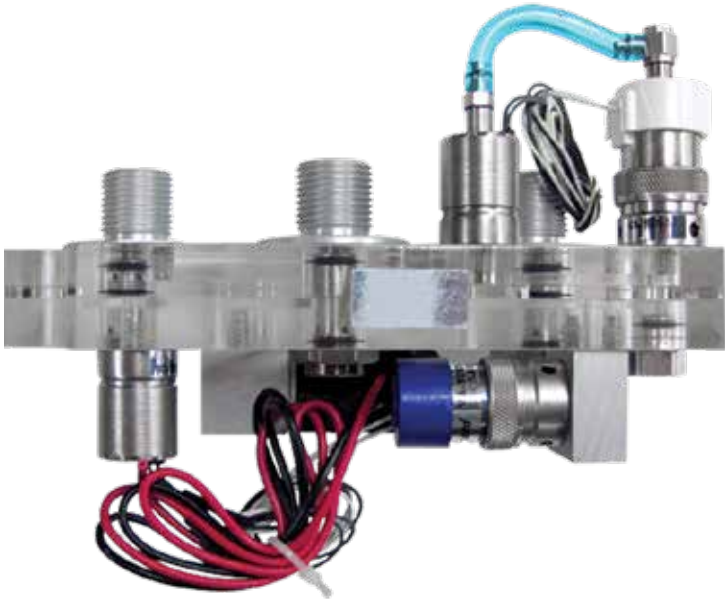

## OXYGEN SERVICE

Due to the high flammability of oxygen, parts used in oxygen-rich environments are extremely sensitive to contamination. Clippard has a number of engineering standards in place that dictate strict cleaning requirements for valves rated for oxygen-rich environments. This includes the standard oxygen clean "O-" series of electronic valves, but can also be applied to customer special orders upon request.

Clippard's cleaning standards for oxygen service include the following:

- Valves are ultrasonically cleaned, assembled, inspected, and tested in a clean room area
- Cleaned parts are inspected under white and ultraviolet light to insure the absence of organic and inorganic contaminants, such as particulate and hydrocarbon contamination
- No organic sealants, adhesives, or lubricants are used in the manufacturing process
- Component parts are lubricated with oxygen-compatible PFPE (perfluoropolyether) grease, only as needed for assembly
- Valves are tested using high purity compressed nitrogen
- Finished valves are double bagged in heat sealed polyethylene bags

## SPECIAL CLEANING REQUIREMENTS

Do you have an application which requires special cleaning for its manufacture, assembly or testing? Clippard is able to provide a wide range of special cleaning, inspection, and testing options for components or assemblies.

Call **877-245-6247** today to discuss how we can accommodate your unique needs, including:

- Ultrasonic cleaning of component parts
- Baking of seals in order to outgas chemicals
- Inspection of cleaned parts under ultraviolet light to detect oil or fibers
- Inspection of cleaned parts under microscopes
- Use of alternate lubricants/sealants or the exclusion of lubricants/sealants from the assembly process
- Testing using high purity compressed nitrogen in place of standard shop air
- Helium leak testing for ultra low leak requirements
- Special packaging of parts to ensure cleanliness



# ORIGINAL EV SERIES MOUSE VALVES

## ELECTRICAL CONNECTION OPTIONS & MOUNTING STYLES

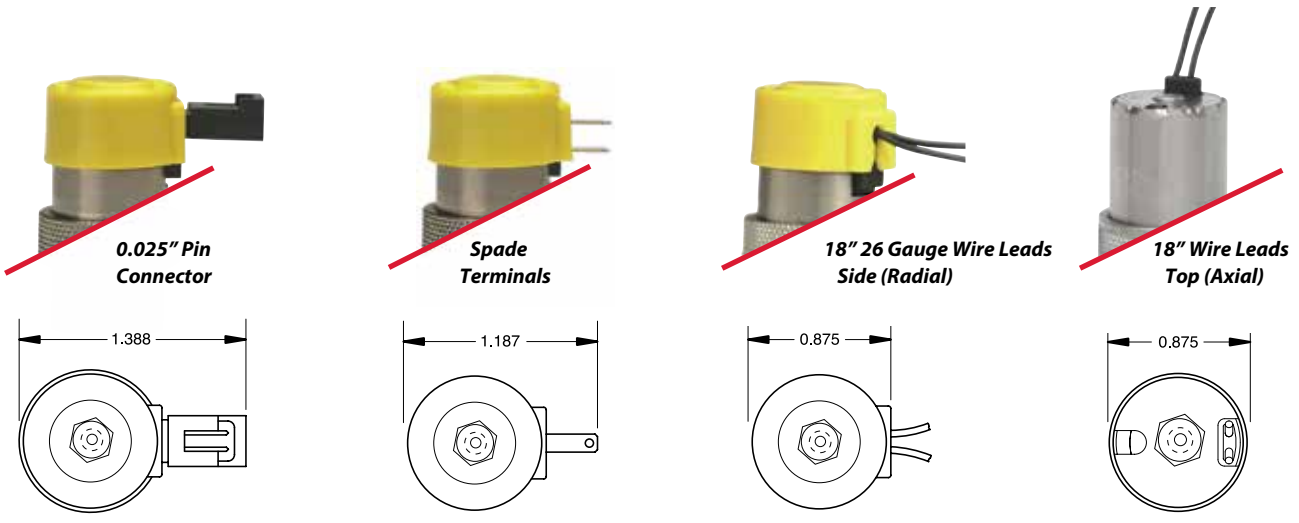

## IN-LINE MOUNT

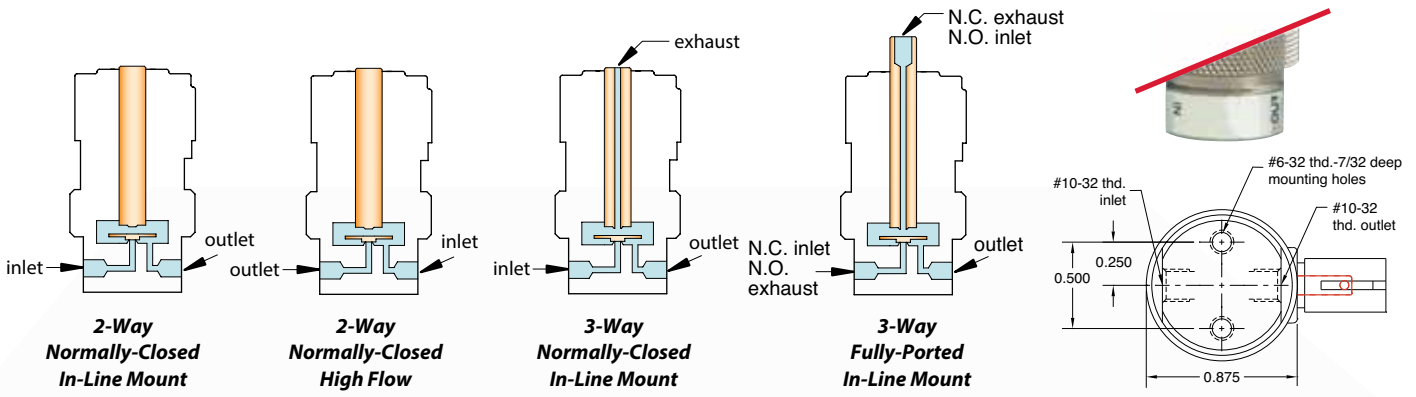

## MANIFOLD MOUNT

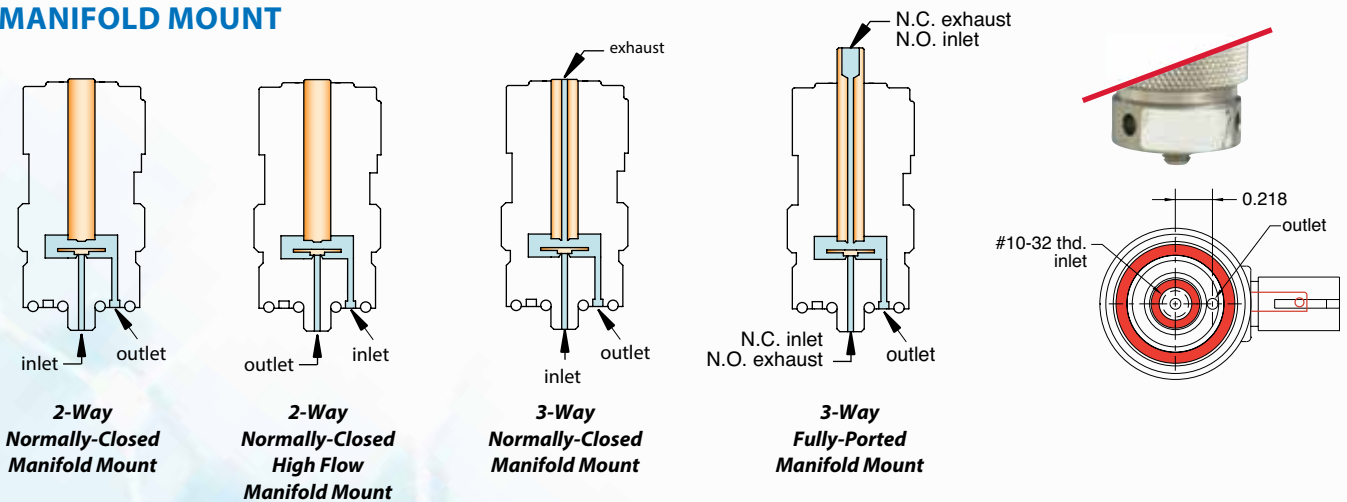

## PROBLEM

It's no surprise that the cleaner your valve is, the less it will leak. However, cleanliness is also important for medical applications where fluid flowing through the valves may be entering a person's body. This requires valves to not only be cleaned of any particulate matter, but also of any harmful substances used in the normal machining or assembly process. In this instance, the OEM's primary concern was that their equipment was not consistently meeting the standards they had set for cleanliness. They were also interested in re-designing the unit to make it smaller.

## SOLUTION

Each of Clippard's manufacturing facilities are equipped with custom isolation enclosures for the assembly, inspection, and testing of sensitive valves and equipment. To eliminate the contamination issues the OEM had been experiencing, their system's valves were replaced with Clippard Oxygen Clean Series EV valves. This line conforms to Clippard's rigorous ES-3.41 cleaning specification which includes ultrasonic cleaning as well as special assembly processes, UV inspection, and high purity compressed nitrogen testing. This insures the absence of any organic or inorganic contaminants. Additionally, because Clippard's valves are 100% tested and calibrated, they also served to increase the system's reliability by providing consistent flow rates.

A standard Clippard manifold allowed the new valves to be closely mounted with a small, compact footprint. This freed up additional space within the unit which contributed to the OEM being able to reduce its overall size. Additionally, the OEM was pleasantly surprised to find that the valves—a standard catalog product, manufactured here in the USA—were always available and shipped quickly, thus eliminating the backorder delays they had been experiencing with their previous supplier.



ELECTRONIC VALVES



WHAT CAN CLIPPARD DO FOR YOU?

877-245-6247



# CUSTOM SOLUTIONS



Clippard understands that often, a standard catalog product may be close but not exactly what your application requires. We frequently provide modifications and custom designs to better suit specific application requirements, and we love a good challenge! Clippard takes great pride in helping customers like you design better products. Smaller, faster, lighter—what are you trying to accomplish? We can help with anything from modified standard products to special manifolds to completely custom products designed for specific, unique applications.

## CONNECTING ENGINEERS WITH ENGINEERS

Our sales team and distributors are invaluable, but our engineers don't like having to relay information through other people any more than yours do. Whenever possible, we prefer to get your technical people speaking directly to ours. This enables more efficient communication and has proven to be one of the best ways to shorten project timelines and ensure mutual success.

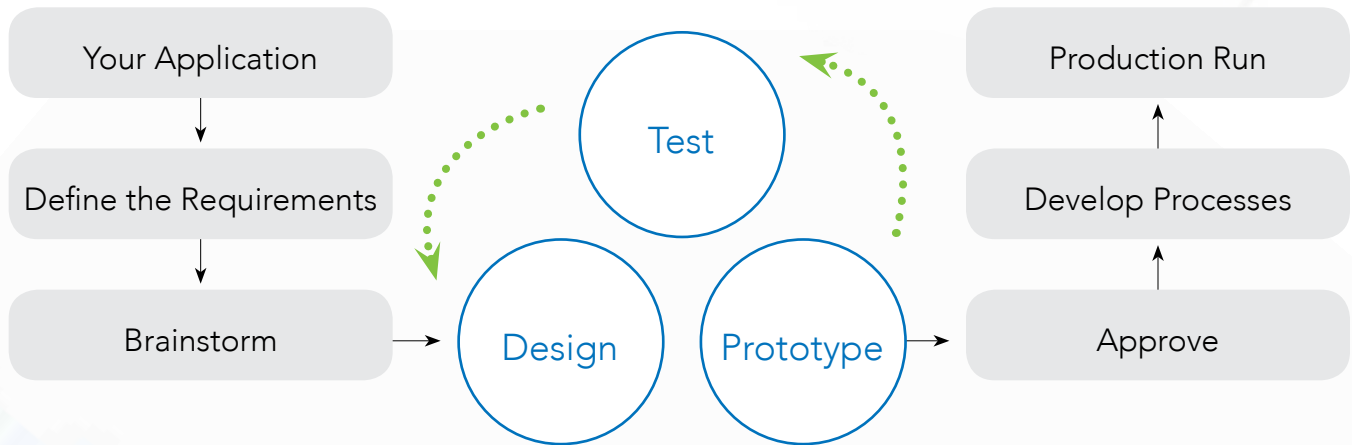

## BENEFITS

- 100% tested sub-assemblies
- Less component inventory
- Fewer vendors and purchase orders
- Less manufacturing time
- Increased production efficiency
- Specialized support
- Overall cost reduction

## OPTIONS

- Special seal materials
- Flow and pressure ranges
- Voltage and power requirements
- Electrical connections
- Ports and connectors
- Mounting configurations
- Oxygen service applications
- Pressure decay testing and helium leak detection

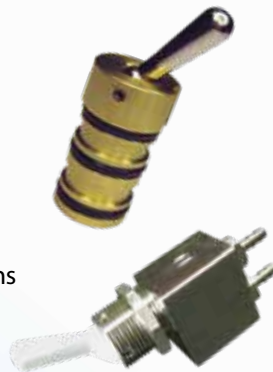

## CAPABILITIES

- Designing compact, easy-to-install assemblies
- Customizing ports and connectors
- Developing integrated solutions
- Manufacturing special manifolds
- Designing pneumatic circuits
- Integrating control boxes and fitting/tubing harnesses
- Assembling and kitting components
- Performing specialized testing
- Providing KanBan services

# ORIGINAL EV SERIES MOUSE VALVES

## FLOW CHART & ELECTRICAL SPECIFICATIONS

### TYPICAL AIR FLOW

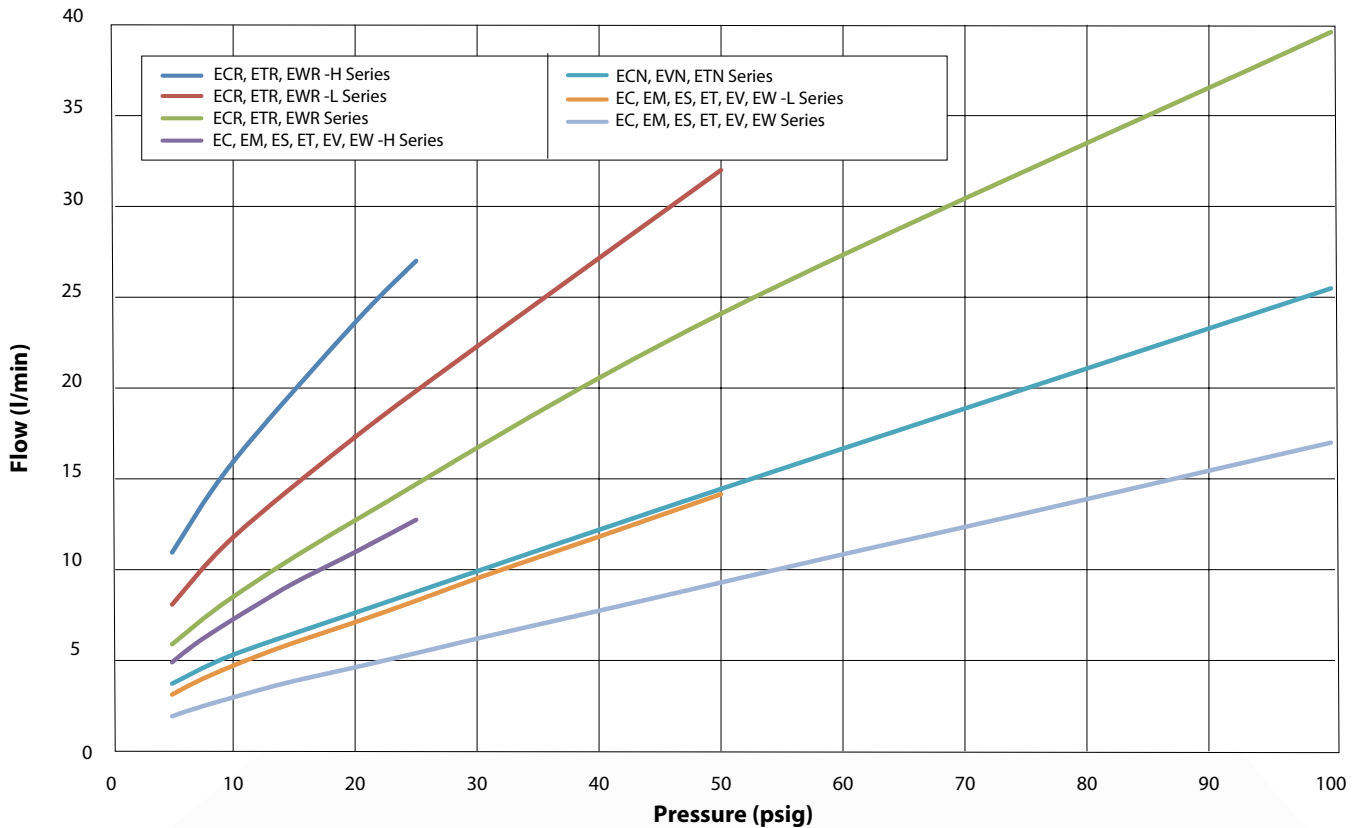

ELECTRONIC VALVES

### ELECTRICAL SPECIFICATIONS

Series	Voltage	Nominal Current	Resistance	Power	Working Range
Standard	12 VDC	0.055 amps	218 ohms	0.67 watts	90 to 150% of rated voltage ( <i>cont. duty</i> )
Oxygen Clean Analytical	24 VDC	0.028 amps	864 ohms		
Corrosion-Resistant	12 VDC	0.098 amps	122 ohms	1.2 watts	90 to 110% of rated voltage ( <i>cont. duty</i> )
	24 VDC	0.049 amps	486 ohms		
EM Series	12 VDC	0.083 amps	144 ohms	1.0 watt	90 to 120% of rated voltage ( <i>cont. duty</i> )
ES Series	24 VDC	0.042 amps	576 ohms		

## Custom Solutions

Many people shy away from asking for custom products, fearing higher prices and longer lead times. However, the reality may surprise you. Clippard's electronic valve production consists of nearly 50% customized products. From simple tweaks to complex challenges, Clippard excels at providing solutions for a wide range of applications.

Contact your local distributor or call **877-245-6247** today to discuss your specific needs.



# ORIGINAL EV SERIES MOUSE VALVES

## 2-WAY N.C. VALVES, IN-LINE & MANIFOLD MOUNT

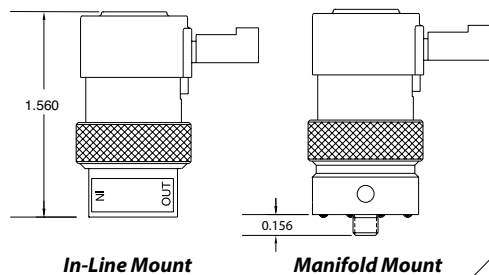

Vac. to 105 psig  
 Vac. to 50 psig  
 Vac. to 25 psig  
 12 VDC  
 24 VDC

		Pressure Range			Voltage		In-Line Mount	Manifold Mount
 0.025" Pin Connector	•			•	•	EC-2-12	EC-2M-12	
	•			•	•	EC-2-24	EC-2M-24	
		•		•	•	EC-2-12-L	EC-2M-12-L	
		•		•	•	EC-2-24-L	EC-2M-24-L	
			•	•	•	EC-2-12-H	EC-2M-12-H	
				•	•	EC-2-24-H	EC-2M-24-H	
 Spade Terminals	•			•	•	ET-2-12	ET-2M-12	
	•			•	•	ET-2-24	ET-2M-24	
		•		•	•	ET-2-12-L	ET-2M-12-L	
		•		•	•	ET-2-24-L	ET-2M-24-L	
			•	•	•	ET-2-12-H	ET-2M-12-H	
				•	•	ET-2-24-H	ET-2M-24-H	
 Wire Leads Side (Radial)	•			•	•	EV-2-12	EV-2M-12	
	•			•	•	EV-2-24	EV-2M-24	
		•		•	•	EV-2-12-L	EV-2M-12-L	
		•		•	•	EV-2-24-L	EV-2M-24-L	
			•	•	•	EV-2-12-H	EV-2M-12-H	
				•	•	EV-2-24-H	EV-2M-24-H	
 Wire Leads Top (Axial)	•			•	•	EW-2-12	EW-2M-12	
	•			•	•	EW-2-24	EW-2M-24	
		•		•	•	EW-2-12-L	EW-2M-12-L	
		•		•	•	EW-2-24-L	EW-2M-24-L	
			•	•	•	EW-2-12-H	EW-2M-12-H	
				•	•	EW-2-24-H	EW-2M-24-H	

<b>Medium</b>	Clean, dry air (40 micron filter)
<b>Power Consumption</b>	0.67 watts; <b>Corrosion-Resistant:</b> 1.2 watts
<b>Temperature Range</b>	32 to 180°F; <b>Corrosion-Resistant:</b> 32 to 150°F
<b>Response Time</b>	5 to 10 ms (nominal)
<b>Operating Range</b>	90 to 150% of rated voltage <b>Corrosion-Resistant:</b> 90 to 110%
<b>Ports</b>	#10-32
<b>Seals</b>	Nitrile standard; FKM, EPDM <sup>1</sup> , and silicone <sup>1</sup> available <b>Oxygen Clean:</b> FKM only <b>Analytical<sup>2</sup>:</b> FKM standard; EPDM <sup>1</sup> , silicone <sup>1</sup> available
<b>More Details</b>	<a href="http://clippard.com/link/ev">clippard.com/link/ev</a>

See p. 10 for mounting option schematics

Valve Series Prefix	Options Suffix
Oxygen Clean	O- Nitrile Seals <sup>3</sup> (blank)
Analytical <sup>2</sup>	A- FKM Seals -V
Corrosion-Resistant	CR- EPDM Seals <sup>1,3</sup> -E
	Silicone Seals <sup>1</sup> -S
	Diode <sup>4</sup> -D

Pressure Range	Air Flow	Options Suffix
28" Hg Vac. to 105 psig	17 l/min @ 100 psig	(blank)
28" Hg Vac. to 50 psig	14 l/min @ 50 psig	-L
28" Hg Vac. to 25 psig	12.5 l/min @ 25 psig	-H

**Example Part Numbers:** ET-2M-12-V; CR-ET-2-12

<sup>1</sup>Minimum order quantity required for EPDM or silicone seals

<sup>2</sup>Analytical series valves available in manifold mount only

<sup>3</sup>Not available for Oxygen Clean or Analytical series valves

<sup>4</sup>Available on EC (pin connector) models only

# HIGH FLOW MOUSE VALVES

## 2-WAY N.C. HIGH FLOW VALVES, IN-LINE & MANIFOLD MOUNT

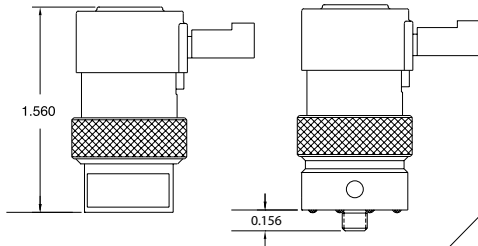

0 to 105 psig

0 to 50 psig

0 to 25 psig

12 VDC

24 VDC

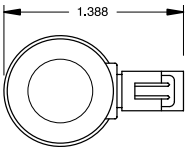
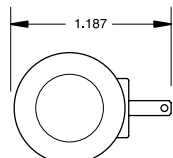
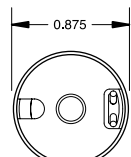
		Pressure Range			Voltage		In-Line Mount	Manifold Mount
 0.025" Pin Connector	•			•		ECR-2-12	ECR-2M-12	
	•			•	•	ECR-2-24	ECR-2M-24	
		•		•		ECR-2-12-L	ECR-2M-12-L	
		•		•	•	ECR-2-24-L	ECR-2M-24-L	
			•	•		ECR-2-12-H	ECR-2M-12-H	
			•	•	•	ECR-2-24-H	ECR-2M-24-H	
 Spade Terminals	•			•		ETR-2-12	ETR-2M-12	
	•			•	•	ETR-2-24	ETR-2M-24	
		•		•		ETR-2-12-L	ETR-2M-12-L	
		•		•	•	ETR-2-24-L	ETR-2M-24-L	
			•	•		ETR-2-12-H	ETR-2M-12-H	
			•	•	•	ETR-2-24-H	ETR-2M-24-H	
 Wire Leads Top (Axial)	•			•		EWR-2-12	EWR-2M-12	
	•			•	•	EWR-2-24	EWR-2M-24	
		•		•		EWR-2-12-L	EWR-2M-12-L	
		•		•	•	EWR-2-24-L	EWR-2M-24-L	
			•	•		EWR-2-12-H	EWR-2M-12-H	
			•	•	•	EWR-2-24-H	EWR-2M-24-H	

<b>Medium</b>	Clean, dry air (40 micron filter)
<b>Power Consumption</b>	1.2 watts
<b>Temperature Range</b>	32 to 150°F
<b>Response Time</b>	5 to 10 ms (nominal)
<b>Operating Range</b>	90 to 110% of rated voltage
<b>Ports</b>	#10-32
<b>Seals</b>	Nitrile standard; FKM, EPDM <sup>1</sup> , and silicone <sup>1</sup> available <b>Analytical<sup>2</sup></b> : FKM standard; EPDM <sup>1</sup> , silicone <sup>1</sup> available
<b>More Details</b>	<a href="http://clippard.com/link/ev">clippard.com/link/ev</a>

Valve Series Prefix	Options Suffix
Analytical <sup>2</sup>	A-
	Nitrile Seals <sup>3</sup>
	FKM Seals
	EPDM Seals <sup>1</sup>
	Silicone Seals <sup>1</sup>
	Diode <sup>4</sup>
	(blank)
	-V
	-E
	-S
	-D

Pressure Range	Air Flow	Options Suffix
0 to 100 psig	39.5 l/min @ 100 psig	(blank)
0 to 50 psig	31 l/min @ 50 psig	-L
0 to 25 psig	27 l/min @ 25 psig	-H

**Example Part Numbers:** ECR-2-12-V; A-EWR-2M-12

<sup>1</sup>Minimum order quantity required for EPDM or silicone seals

<sup>2</sup>Analytical series valves available in manifold mount only

<sup>3</sup>Not available for Analytical series valves





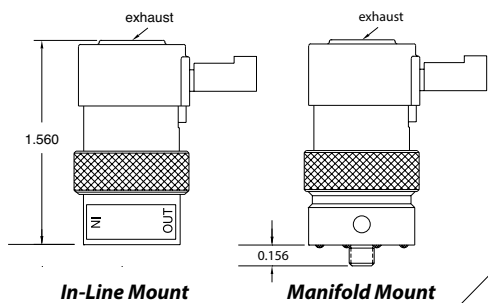

<sup>4</sup>Available on EC (pin connector) models only

See p. 10 for mounting option schematics

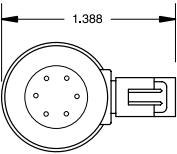
# ORIGINAL EV SERIES MOUSE VALVES

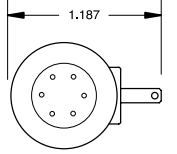
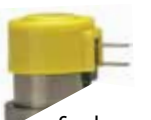
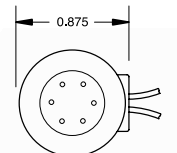
## 3-WAY N.C. VALVES, IN-LINE & MANIFOLD

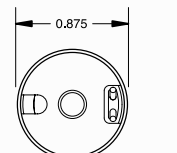

		Pressure Range			Voltage		In-Line Mount	Manifold Mount
 0.025" Pin Connector		•	•	•	•	•	EC-3-12	EC-3M-12
		•	•	•	•	•	EC-3-24	EC-3M-24
		•	•	•	•	•	EC-3-12-L	EC-3M-12-L
		•	•	•	•	•	EC-3-24-L	EC-3M-24-L
		•	•	•	•	•	EC-3-12-H	EC-3M-12-H
•	•	•	•	•	EC-3-24-H	EC-3M-24-H		
 Spade Terminals		•	•	•	•	•	ET-3-12	ET-3M-12
		•	•	•	•	•	ET-3-24	ET-3M-24
		•	•	•	•	•	ET-3-12-L	ET-3M-12-L
		•	•	•	•	•	ET-3-24-L	ET-3M-24-L
		•	•	•	•	•	ET-3-12-H	ET-3M-12-H
•	•	•	•	•	ET-3-24-H	ET-3M-24-H		
 Wire Leads Side (Radial)		•	•	•	•	•	EV-3-12	EV-3M-12
		•	•	•	•	•	EV-3-24	EV-3M-24
		•	•	•	•	•	EV-3-12-L	EV-3M-12-L
		•	•	•	•	•	EV-3-24-L	EV-3M-24-L
		•	•	•	•	•	EV-3-12-H	EV-3M-12-H
•	•	•	•	•	EV-3-24-H	EV-3M-24-H		
 Wire Leads Top (Axial)		•	•	•	•	•	EW-3-12	EW-3M-12
		•	•	•	•	•	EW-3-24	EW-3M-24
		•	•	•	•	•	EW-3-12-L	EW-3M-12-L
		•	•	•	•	•	EW-3-24-L	EW-3M-24-L
		•	•	•	•	•	EW-3-12-H	EW-3M-12-H
•	•	•	•	•	EW-3-24-H	EW-3M-24-H		

<b>Medium</b>	Clean, dry air (40 micron filter)
<b>Power Consumption</b>	0.67 watts; <b>Corrosion-Resistant:</b> 1.2 watts
<b>Temperature Range</b>	32 to 180°F; <b>Corrosion-Resistant:</b> 32 to 150°F
<b>Response Time</b>	5 to 10 ms (nominal)
<b>Operating Range</b>	<b>Standard:</b> 90 to 150% of rated voltage <b>Corrosion-Resistant:</b> 90 to 110%
<b>Ports</b>	#10-32
<b>Seals</b>	Nitrile standard; FKM, EPDM <sup>1</sup> , and silicone <sup>1</sup> available <b>Oxygen Clean:</b> FKM only <b>Analytical<sup>2</sup>:</b> FKM standard; EPDM <sup>1</sup> , silicone <sup>1</sup> available
<b>More Details</b>	<a href="http://clippard.com/link/ev">clippard.com/link/ev</a>

See p. 10 for mounting option schematics

Valve Series Prefix		Options Suffix	
Oxygen Clean	A-	Nitrile Seals <sup>3</sup>	(blank)
Analytical <sup>2</sup>	CR-	FKM Seals	-V
Corrosion-Resistant		EPDM Seals <sup>1,3</sup>	-E
		Silicone Seals <sup>1,3</sup>	-S
		Diode <sup>4</sup>	-D

Pressure Range	Air Flow	Options Suffix
28" Hg Vac. to 105 psig	17 l/min @ 100 psig	(blank)
28" Hg Vac. to 50 psig	14 l/min @ 50 psig	-L
28" Hg Vac. to 25 psig	12.5 l/min @ 25 psig	-H

**Example Part Numbers:** ET-3-12-S; O-EW-3-24

<sup>1</sup>Minimum order quantity required for EPDM or silicone seals

<sup>2</sup>Analytical series valves available in manifold mount only

<sup>3</sup>Not available for Oxygen Clean or Analytical series valves







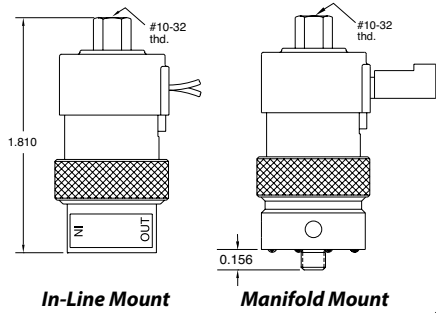

<sup>4</sup>Available on EC (pin connector) models only

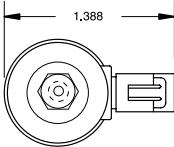
# ORIGINAL EV SERIES MOUSE VALVES

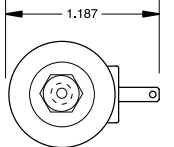
## 3-WAY FULLY-PORTED VALVES, IN-LINE & MANIFOLD

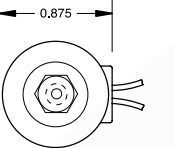

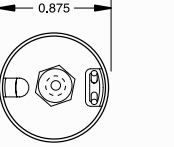
Vac. to 105 psig  
 Vac. to 50 psig  
 Vac. to 25 psig  
 12 VDC  
 24 VDC

		Pressure Range			Voltage		In-Line Mount	Manifold Mount
 0.025" Pin Connector		•			•		ECO-3-12	ECO-3M-12
		•			•		ECO-3-24	ECO-3M-24
			•		•		ECO-3-12-L	ECO-3M-12-L
			•		•		ECO-3-24-L	ECO-3M-24-L
			•		•		ECO-3-12-H	ECO-3M-12-H
	•		•		ECO-3-24-H	ECO-3M-24-H		
 Spade Terminals		•			•		ETO-3-12	ETO-3M-12
		•			•		ETO-3-24	ETO-3M-24
			•		•		ETO-3-12-L	ETO-3M-12-L
			•		•		ETO-3-24-L	ETO-3M-24-L
			•		•		ETO-3-12-H	ETO-3M-12-H
	•		•		ETO-3-24-H	ETO-3M-24-H		
 Wire Leads Side (Radial)		•			•		EVO-3-12	EVO-3M-12
		•			•		EVO-3-24	EVO-3M-24
			•		•		EVO-3-12-L	EVO-3M-12-L
			•		•		EVO-3-24-L	EVO-3M-24-L
			•		•		EVO-3-12-H	EVO-3M-12-H
	•		•		EVO-3-24-H	EVO-3M-24-H		
 Wire Leads Top (Axial)		•			•		EWO-3-12	EWO-3M-12
		•			•		EWO-3-24	EWO-3M-24
			•		•		EWO-3-12-L	EWO-3M-12-L
			•		•		EWO-3-24-L	EWO-3M-24-L
			•		•		EWO-3-12-H	EWO-3M-12-H
	•		•		EWO-3-24-H	EWO-3M-24-H		

<b>Medium</b>	Clean, dry air (40 micron filter)
<b>Power Consumption</b>	0.67 watts; <b>Corrosion-Resistant:</b> 1.2 watts
<b>Temperature Range</b>	32 to 180°F; <b>Corrosion-Resistant:</b> 32 to 150°F
<b>Response Time</b>	5 to 10 ms (nominal)
<b>Operating Range</b>	90 to 150% of rated voltage <b>Corrosion-Resistant:</b> ±10%
<b>Ports</b>	#10-32
<b>Seals</b>	Nitrile standard; FKM, EPDM <sup>1</sup> , and silicone <sup>1</sup> available <b>Oxygen Clean:</b> FKM only <b>Analytical<sup>2</sup>:</b> FKM standard; EPDM <sup>1</sup> , silicone <sup>1</sup> available
<b>More Details</b>	<a href="http://clippard.com/link/ev">clippard.com/link/ev</a>

See p. 10 for mounting option schematics

Valve Series Prefix		Options Suffix	
Oxygen Clean	O-	Nitrile Seals <sup>3</sup>	(blank)
Analytical <sup>2</sup>	A-	FKM Seals	-V
Corrosion-Resistant	CR-	EPDM Seals <sup>1</sup>	-E
		Silicone Seals <sup>1</sup>	-S
		Diode <sup>4</sup>	-D

Pressure Range	Air Flow	Options Suffix
28" Hg Vac. to 105 psig	17 l/min @ 100 psig	(blank)
28" Hg Vac. to 50 psig	14 l/min @ 50 psig	-L
28" Hg Vac. to 25 psig	12.5 l/min @ 25 psig	-H

**Example Part Numbers:** ETO-3M-24-D; CR-EVO-3-12

<sup>1</sup>Minimum order quantity required for EPDM or silicone seals

<sup>2</sup>Analytical series valves available in manifold mount only

<sup>3</sup>Not available for Oxygen Clean or Analytical series valves

<sup>4</sup>Available on EC (pin connector) models only

# ECN, ETN, EVN SERIES MOUSE VALVES

## 2-WAY & 3-WAY N.O. VALVES, MANIFOLD

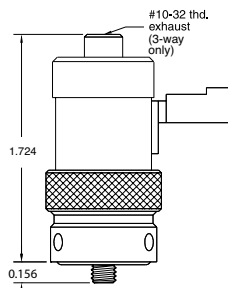

12 VDC

24 VDC

		Voltage	2-Way	3-Way
	 0.025" Pin Connector	•	ECN-2M-12	ECN-3M-12
		•	ECN-2M-24	ECN-3M-24
	 Spade Terminals	•	ETN-2M-12	ETN-3M-12
		•	ETN-2M-24	ETN-3M-24
	 Wire Leads Side (Radial)	•	EVN-2M-12	EVN-3M-12
		•	EVN-2M-24	EVN-3M-24

<b>Medium</b>	Clean, dry air (40 micron filter)
<b>Power Consumption</b>	0.67 watts
<b>Temperature Range</b>	32 to 180°F
<b>Response Time</b>	5 to 10 ms (nominal)
<b>Operating Range</b>	90 to 150% of rated voltage
<b>Voltage</b>	12 VDC or 24 VDC; other voltages available
<b>Ports</b>	#10-32
<b>Seals</b>	Nitrile standard; FKM, EPDM <sup>1</sup> , and silicone <sup>1</sup> available
<b>More Details</b>	<a href="http://clippard.com/link/ecn">clippard.com/link/ecn</a>

See p. 10 for mounting option schematics

### Pressure Range | Air Flow

28" Hg Vac. to 105 psig

25 l/min @ 100 psig

### Options Suffix

Nitrile Seals	(blank)
FKM Seals	-V
EPDM Seals <sup>1</sup>	-E
Silicone Seals <sup>1</sup>	-S
Diode <sup>2</sup>	-D

**Example Part Numbers:** EVN-2M-12-V; ETN-3M-24

<sup>1</sup>Minimum order quantity required for EPDM or silicone seals

<sup>2</sup>Diode available on ECN (pin connector) models only

# INTRINSICALLY SAFE MOUSE VALVES

## 2-WAY & 3-WAY N.C. VALVES, IN-LINE & MANIFOLD

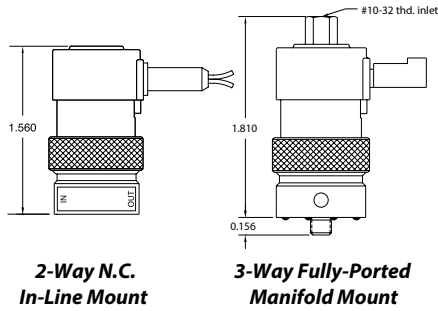

Vac. to 105 psig  
 Vac. to 50 psig  
 Vac. to 25 psig

		Pressure Range		In-Line Mount	Manifold Mount
2-Way Normally-Closed	 0.025" Pin Connector	•		EI-2-15.5	EI-2M-15.5
			•	EI-2-15.5-L	EI-2M-15.5-L
			•	EI-2-15.5-H	EI-2M-15.5-H
	 18 Gauge Leads	•		EI-2-15.5-C	EI-2M-15.5-C
			•	EI-2-15.5-LC	EI-2M-15.5-LC
			•	EI-2-15.5-HC	EI-2M-15.5-HC
3-Way Normally-Closed	 0.025" Pin Connector	•		EI-3-15.5	EI-3M-15.5
			•	EI-3-15.5-L	EI-3M-15.5-L
			•	EI-3-15.5-H	EI-3M-15.5-H
	 18 Gauge Leads	•		EI-3-15.5-C	EI-3M-15.5-C
			•	EI-3-15.5-LC	EI-3M-15.5-LC
			•	EI-3-15.5-HC	EI-3M-15.5-HC
3-Way Fully-Ported	 0.025" Pin Connector	•		EIO-3-15.5	EIO-3M-15.5
			•	EIO-3-15.5-L	EIO-3M-15.5-L
			•	EIO-3-15.5-H	EIO-3M-15.5-H
	 18 Gauge Leads	•		EIO-3-15.5-C	EIO-3M-15.5-C
			•	EIO-3-15.5-LC	EIO-3M-15.5-LC
			•	EIO-3-15.5-HC	EIO-3M-15.5-HC

<b>Medium</b>	Clean, dry air (40 micron filter)
<b>Power Consumption</b>	0.67 watts
<b>Temperature Range</b>	32 to 104°F
<b>Response Time</b>	5 to 10 ms (nominal)
<b>Operating Range</b>	90 to 150% of rated voltage
<b>Voltage</b>	15.5 VDC
<b>Ports</b>	#10-32 and manifold mount
<b>Seals</b>	Nitrile standard; FKM and EPDM <sup>1</sup> available
<b>More Details</b>	<a href="http://clippard.com/link/analytical">clippard.com/link/analytical</a>

Pressure Range	Air Flow	Options Suffix
28" Hg Vac. to 105 psig	17 l/min @ 100 psig	(blank)
28" Hg Vac. to 50 psig	14 l/min @ 50 psig	-L
28" Hg Vac. to 25 psig	12.5 l/min @ 25 psig	-H

Options Suffix	
Nitrile Seals	(blank)
FKM Seals	-V
EPDM Seals <sup>1</sup>	-E

**Example Part Numbers:** EIO-3-15.5-LC; EI-2-15.5

<sup>1</sup>Minimum order quantity required for EPDM seals

See p. 10 for mounting option schematics



# MOUSE VALVE MANIFOLDS

## OXYGEN CLEAN

Oxygen series products are specially manufactured and assembled for applications in oxygen-enriched environments. Each manifold is cleaned according to Clippard Specification #ES-3.41 and double bagged in heat sealed polyethylene bags.

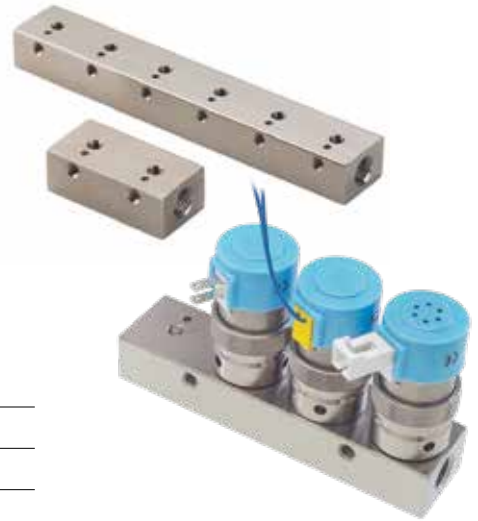

Part No.	Description
O-15581-2	Single-Sided, 2-Station
O-15581-4	Single-Sided, 4-Station
O-15581-6	Single-Sided, 6-Station
O-15582-8	Double-Sided, 8-Station
O-15582-12	Double-Sided, 12-Station

<b>Input Ports</b>	In-line 1/8" NPT
<b>Outlet Ports</b>	#10-32
<b>Mounting</b>	#10-32 tapped holes
<b>Materials</b>	ENP Brass

## MULTI-VALVE MANIFOLDS



Black anodized aluminum

Part No.	Description
15481-2	Single-Sided, 2-Station
15481-4	Single-Sided, 4-Station
15481-6	Single-Sided, 6-Station
15482-8	Double-Sided, 8-Station
15482-12	Double-Sided, 12-Station

## ET VALVE CONNECTORS



Black molded lug connectors are available for easy push-on connection

Part No.	Description
ET-C48	48° Connector
ET-C120	120° Connector

## EC & EI CONNECTORS



TE Connectivity #5-103956-1 for EC/ECO and EI/EIO valves

Part No.	Description
C2-RB18	18° Connector
C2-RB120	120° Connector

## SPECIALIZED MANIFOLDS *ENP brass and oxygen clean also available*



15490-2 shown

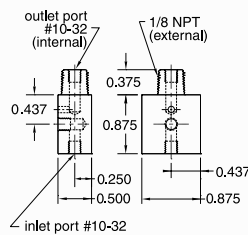

**Part No.** 15490-1  
**Description** #10-32 Inlet, 1/8" NPT Outlet

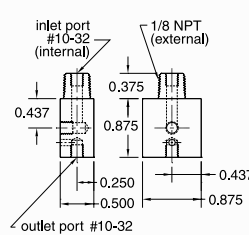

**Part No.** 15490-2  
**Description** 1/8" NPT Inlet, #10-32 Outlet

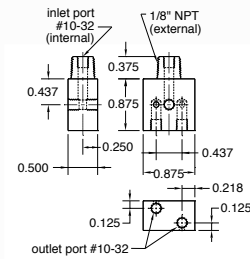

**Part No.** 15490-3 Dual Outlet  
**Description** 1/8" NPT Inlet, #10-32 Outlet



15491-1 shown

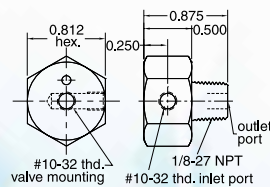

**Part No.** 15491-1  
**Description** #10-32 Inlet, 1/8" NPT Outlet

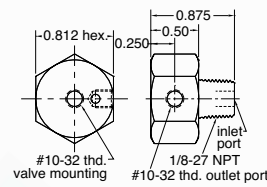

**Part No.** 15491-2  
**Description** 1/8" NPT Inlet, #10-32 Outlet

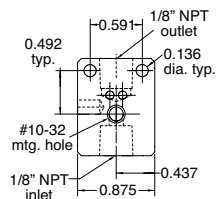

**Part No.** 15490-5  
**Description** 1/8" NPT Inlet, 1/8" NPT Outlet

# Clippard Electronic Manifold Cards

## Auxiliary Power Input

Power to operate the valves may be provided through two sources: ONE, through the 25-pin connector if your signal source also has sufficient power to operate the bank of valves, or TWO, through a separate auxiliary power input connection built into the board. To isolate power use the power source selector switch.

## Reverse Polarity Protection

Circuit using diodes and capacitor provides input voltage protection against reverse polarity.

Note: In applying power on a temporary basis, use care to observe proper circuit polarity.

## Power Selector Switch

Enables choice of power input source (25-pin connector or auxiliary).

## Printed Circuit Board

Durable laminated fiberglass



To configure manifold cards, visit [clippard.com/link/mc](http://clippard.com/link/mc)

## Resistor-Diode-LED Circuit

Individual circuit to each valve provides protection against shut-off spikes. LED is illuminated when valve is actuated.

## 25-Pin Connector

## Clippard Valve Manifold

Compact, efficient mounting of the valves is achieved with Clippard multi-valve manifolds.

## 3-Position Detented Switches

Provides for ON power, valve is activated; OFF power, valve is not connected; CONN valve is connected to 25-pin connector and will be controlled through it.

## Clippard Electronic Valves

## LED Bank

Illuminated LED signals that the valve is actuated.

Now you can direct low-voltage DC signals from controllers, systems, computers, or other sources to operate powerful pneumatic valves with a minimum of piping and hook-up.

### Self-contained card includes:

- 8 or 12 Clippard ET interface valves
- Manifold mount for single air supply
- Circuit board fully wired
- Instant plug-in with 25-pin connector
- Resistor, diode, LED and switch for each valve
- Auxiliary power supply connection

- Fast, easy to mount
- Pre-assembled; all valves mounted
- Low power requirements (0.67 watt per valve)
- Choice of valve types
- Each valve switchable
- Shut-off spike protection
- No expensive card rack required